

**ASSEMBLY INSTRUCTION**  
**KENORA 4 DRAWER TALL CHEST**  
**ITEM CODE : 85190**

Imported by Amart Furniture Pty Ltd, Qld, Brisbane Australia.  
For any assistance with assembly or for missing parts please phone  
Amart Furniture Pty Ltd Customer Service Free call 1800 351 084

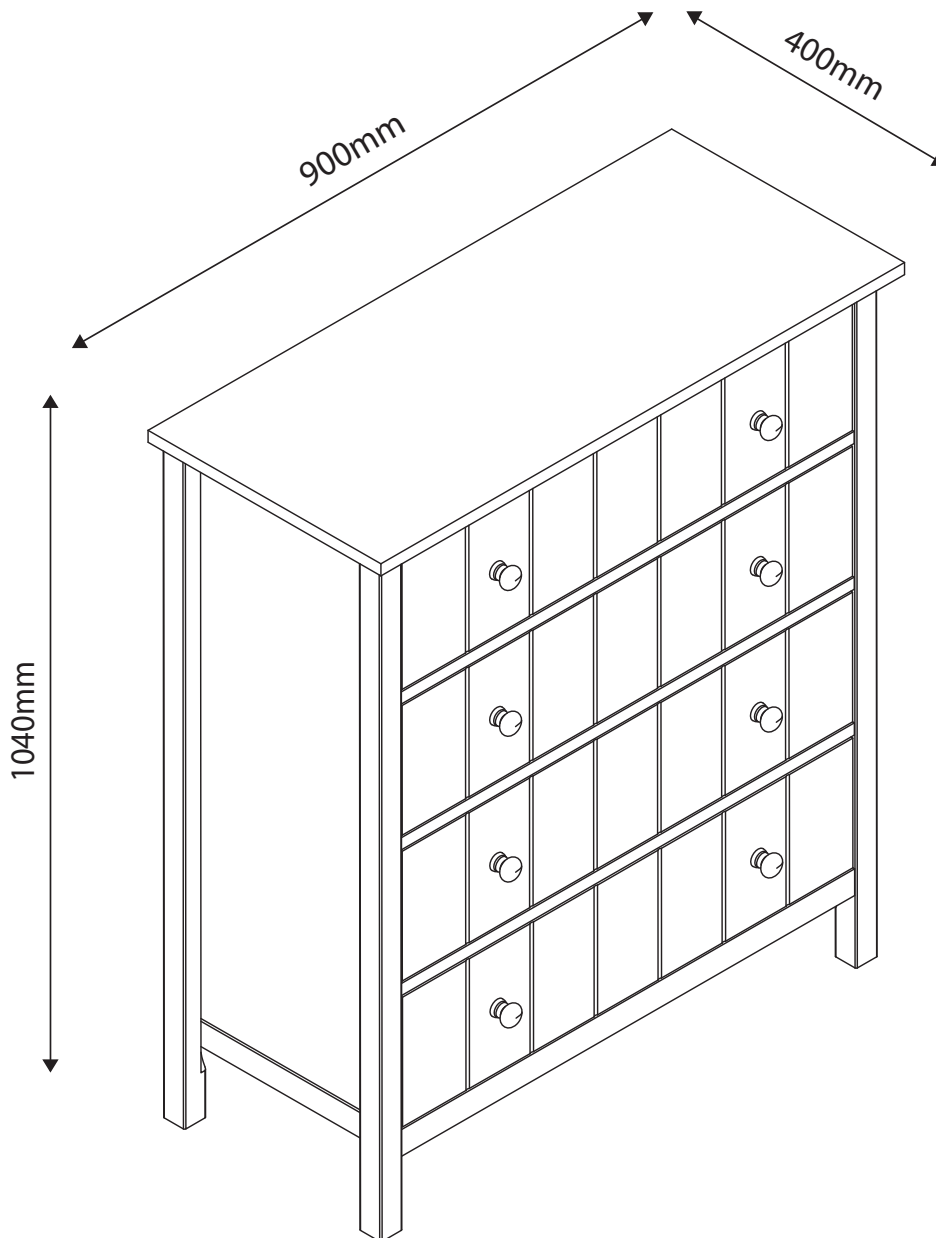





Imported by Amart Furniture Pty Ltd, Qld, Brisbane Australia.  
For any assistance with assembly or for missing parts please phone  
Amart Furniture Pty Ltd, Customer Service Free call 1800 351 084

## PRE-ASSEMBLY PREPARATION

### Before you start:

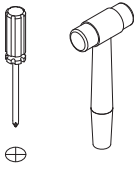
1. Choose a clean, level, spacious assembly area. Avoid hard surfaces that may damage the product.
2. Take care when lifting. Product should be assembled as near as possible to the point of use.
3. Ensure that you have all required contents for complete assembly.
4. Always read the assembly instructions carefully before beginning assembly.
5. Keep all hardware parts and packaging out of reach of small children.
6. Do not over tighten the screws and bolts as this may damage the threads.

	
<b>ALLOW 10 MINUTES</b>	<b>1 PERSON REQUIRED</b>
	
<b>ADDITIONAL TOOLS REQUIRED</b>	<b>NO POWER DRILL</b>

<b>⚠ WARNING</b>		
		<p><b>Children have died from furniture tipover.</b></p> <ul style="list-style-type: none"><li>• ALWAYS secure it with an anchor device.</li><li>• NEVER allow children to stand, climb or hang on drawers, doors, or shelves.</li><li>• NEVER open more than one drawer at a time.</li><li>• Place heavy items down low</li></ul> <p><b>NEVER put a TV on this furniture</b> </p> <p><b>This is a permanent label. Do not remove!</b></p>

## ANTI TIPPING KIT INSTALLATION INSTRUCTION

1. Attach the bracket to the back top rail of the furniture using the 18mm screw provided through the small hole.
2. Locate the other bracket on the wall 50mm below the bracket on the unit. Care should be taken to ensure that this is securely fastened to the wall. The best method of fixing will depend upon the construction of the wall. Please note we do not supply fittings for this purpose as the type of fixing required will vary depending upon your wall.
3. Place the furniture into position so both mounting brackets are vertically in line.
4. Lace the end of the restraint strap through the larger hole in each mounting bracket. Bring both ends together and slide the flat end through the locking end and draw it through until all slack is removed.
5. Confirm that the strap is securely laced and locked.

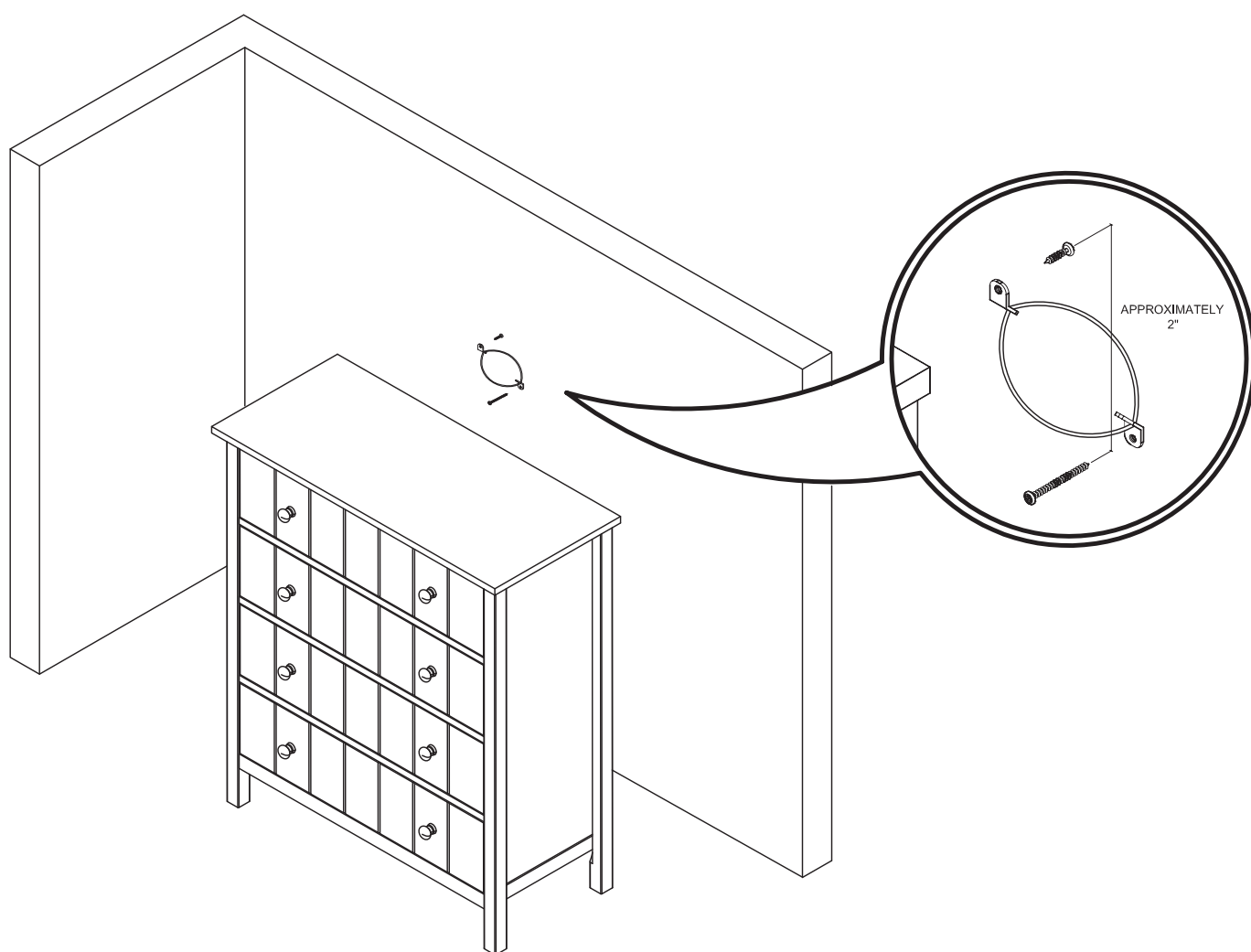

**Anti Tipping Kit ( 1 Pack ) :**

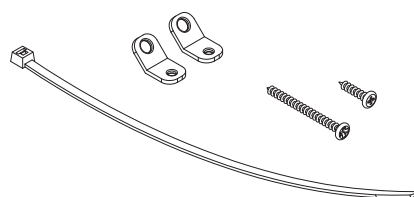

*To attach the top shelving to the wall for added safety.*

## **IMPORTANT : PRODUCT CARE FOR TIMBER ITEMS**

As our timber is supplied from sustainable forests there will be natural variations in surface texture and grain like knots, mineral streaks and sap runs that may affect the finish. These differences in character are not defects, but distinctions that make each piece of furniture unique.

Our furniture is built to last. Following these steps for basic care should protect your investment for years to come.

- Dust frequently with a clean damp lint-free cloth. This will help remove abrasive build up which can damage a finish over time.
- Do not place hot objects on any furniture surface. Always use a hot plate or placemat. Laminate and lacquer finishes on table tops provide added scratch and heat resistance to our furniture, but they can still be damaged without proper care.
- Avoid exposing your furniture to strong sunlight, heat outlet, open windows or dampness. Prolonged exposure to direct sunlight can fade the finish of your furniture, while extreme temperature and humidity changes can cause cracking or splitting.
- Do not expose your furniture to any liquids. Never allow water to sit on your furniture. Alcohol, nail polish and perfume are also dangerous as they will dissolve the lacquer finish on contact and may require professional repairs.
- Do not allow plastic to come in direct contact with your furniture. Chemicals in plastic of placemats etc. may soften and mark the finish if left in contact with the furniture for a period of time.